

Table II. Association Constants and Thermodynamic Properties of Tetracyanoethylene Complexes in Cyclohexane

Donor	Temp, °C	K_x	ϵ_{\max}^a	
Ferrocene ^a	30	30.0	474	$\Delta H_f = -3800$ cal/mole
	40	25.5	474	$\Delta S_f = -5.5$ eu
	50	21.0	469	
	60	17.5	474	
	70	15.0	479	
1,1'-Dimethyl-ferrocene ^b	30	52.0	462	$\Delta H_f = -4300$ cal/mole
	40	39.5	475	$\Delta S_f = -6.4$ eu
	50	31.9	472	
	60	26.5	464	
	70	21.5	472	

^a Average of two separate determinations. ^b Average of three separate determinations. ^c λ_{\max} for ferrocene-TCNE 1000 m μ , and for 1,1'-dimethylferrocene-TCNE 1025 m μ .

in which steric interactions between the substituted donor and the acceptor component are minimized, than by structure 2.

Acknowledgment. This work was supported by Grant No. GP-4550 from the National Science Foundation and by Grant No. GM-05978 from the National Institutes of Health.

Elinor Adman, M. Rosenblum, S. Sullivan, T. N. Margulis
Department of Chemistry, Brandeis University
Waltham, Massachusetts 02154
Received April 24, 1967

Insertion of Dichlorocarbene into a Carbon-Hydrogen Bond with Net Inversion of Configuration

Sir:

Recent reports have indicated an unusual and very specific preference for dichlorocarbene insertion into carbon-hydrogen bonds located β to either silicon,¹ tin,¹ or mercury.² The stereochemistry of this reaction is of particular interest with regard to the evaluation of possible mechanistic pathways.

(+)-Bis((*S*)-2-methylbutyl)mercury (1), $[\alpha]^{27.5D} + 8.01^\circ$ (neat)³ was prepared from 98% optically pure (*S*)-(-)-2-methyl-1-butanol (Aldrich) via the intermediate chloride. The configuration of 1 has been well

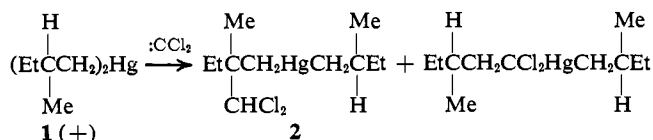

established by simple chemical transformations which allow a direct correlation with (-)-isoleucine,^{6,7} the absolute configuration of which has been determined by X-ray diffraction studies.⁸ Treatment of 1 with ethyl trichloroacetate and excess sodium methoxide in pentane resulted in the formation of the carbon-hydro-

(1) D. Seyferth and S. S. Washburne, *J. Organometal. Chem.* (Amsterdam), **5**, 389 (1966).

(2) J. A. Landgrebe and R. D. Mathis, *J. Am. Chem. Soc.*, **88**, 3545 (1966).

(3) Values of $+7.65$ ($\leq 95\%$ optical purity)⁴ and $+7.82^\circ$ have been previously reported.

(4) S. Murahashi, S. Nuzakura, and S. Takeuchi, *Bull. Chem. Soc. Japan*, **33**, 658 (1966).

(5) G. Frankel and D. T. Dix, *J. Am. Chem. Soc.*, **88**, 979 (1966).

(6) W. S. Foues, *ibid.*, **76**, 1377 (1954).

(7) E. J. Badin and E. Pacsu, *ibid.*, **67**, 1352 (1945).

(8) J. Trommel and J. M. Bijvoet, *Acta Cryst.*, **7**, 703 (1954).

gen insertion product 2 and the corresponding carbon-mercury bond insertion product² in a ratio of $\sim 93:7$.

Purified 2 was then cleaved with bromine in carbon tetrachloride to give a mixture of (-)-1,1-dichloro-2-(bromomethyl)-2-methylbutane (3), $[\alpha]^{25D} -1.13^\circ$

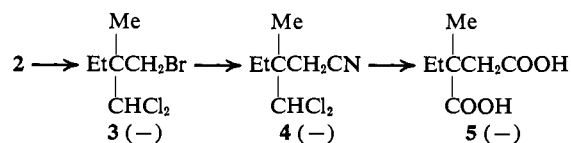

(CHCl₃), and (+)-1-bromo-2-methylbutane. Trihalide 3 was converted to nitrile 4, $[\alpha]^{25D} -1.61^\circ$ (CHCl₃), in low yield by treatment with sodium cyanide in dimethyl sulfoxide (50–90°), and the nitrile was hydrolyzed and oxidized with a basic aqueous silver oxide suspension to give (*S*)-(-)- α -methyl- α -ethylsuccinic acid (5), $[\alpha]^{25D} -6.41^\circ$ (CHCl₃).^{9,10} The method of quasi-racemates has been used to establish the relative configuration of 5 with that of each of a series of α -monosubstituted and α -disubstituted succinic acids,^{12,13} including α -methylsuccinic acid, the absolute configuration of which was recently established by X-ray diffraction techniques.¹⁴

The results clearly indicate that the insertion of dichlorocarbene into the β -carbon-hydrogen bond of 1 has occurred with *net inversion of configuration*, an unprecedented stereochemical result for a divalent carbon insertion process.² One can therefore rule out any mechanistic path which requires a direct attack of the divalent carbon atom on the carbon-hydrogen bonding electrons or a direct transfer of dichlorocarbene into the carbon-hydrogen bond *via* an ylide intermediate, as has been postulated for the analogous reaction in the tetraalkylsilane series.¹

(9) Average of values for two independent conversions of 3 to 5 with an average deviation of $\pm 0.4^\circ$.

(10) The rotation of the resolved acid has been reported as $[\alpha]^{25D} -5.92^\circ$ (CHCl₃).¹¹

(11) S. Stallberg-Stenhagen, *Arkiv Kemi*, **3**, 273 (1951).

(12) J. Porath, *ibid.*, **3**, 163 (1951).

(13) α -Substituted succinic acids of the same configuration were shown to have the same sign of rotation.¹²

(14) A. T. McPhail, G. A. Sim, J. D. M. Asher, J. M. Robertson, and J. V. Silverton, *J. Chem. Soc., Phys. Org. Sect.*, **18** (1966).

John A. Landgrebe, Duane E. Thurman
Department of Chemistry, University of Kansas
Lawrence, Kansas 66044
Received May 5, 1967

Nuclear Magnetic Resonance of Phosphorus Compounds. III. Phosphorus-31 Overhauser Effects and Utilization of Simultaneous Observation of the Spectra of Two Types of Nuclei in Double-Resonance Experiments^{1,2}

Sir:

In homonuclear magnetic double-resonance experiments it is possible by irradiation of one or more transitions to achieve departures from thermal spin distributions with concomitant redistribution of spectral line intensities.³ Although observed signal-intensity

(1) This paper presents the results of one phase of research carried out at the Jet Propulsion Laboratory, California Institute of Technology, under Contract No. NAS7-100, sponsored by the National Aeronautics and Space Administration.

(2) Previous paper in this series: S. L. Manatt, G. L. Juvinal, R. I. Wagner, and D. D. Elleman, *J. Am. Chem. Soc.*, **88**, 2689 (1966).

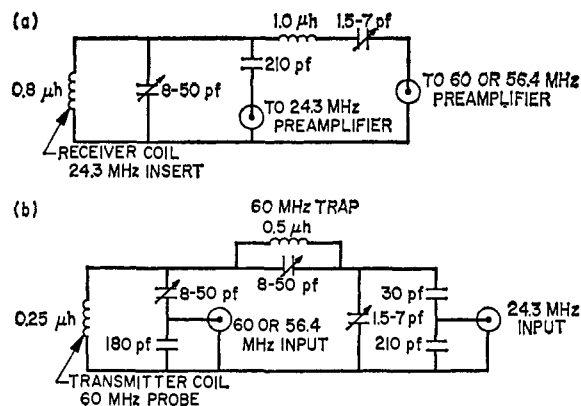

Figure 1. Modification to V-4331A 60-Mc probe circuits for operation at 24.3 and 60 MHz or 24.3 and 56.4 MHz: (a) receiver; (b) transmitter.

perturbations in the range of -150 to $+50\%$ have been observed in ^1H - $[^1\text{H}]$ experiments with weak perturbing fields, simple consideration^{3b,d,e} of the energy level populations of a nuclear spin system in heteronuclear double-resonance experiments suggests for a ratio of magnetogyric ratios of two or greater that in the spectrum of the lower magnetogyric ratio nucleus much larger intensity changes are to be expected. There appear to be no reports of such experiments with weak perturbing fields. However, there have been a few incidences of the use of fields of sufficient magnitude to accomplish complete decoupling of higher magnetogyric nuclei.⁴ From the limited available data, application of this latter technique in ^{13}C - $[^1\text{H}]$ experiments appears to result in signal enhancement factors⁵ in the range of 0.5–1.8 over those expected for complete collapse of the multiplet structures from spin-spin coupling.^{4e,6} We present below some results for the ^{31}P nmr signal intensity changes in experiments involving both weak perturbing fields and strong fields.

We have modified our spectrometer⁷ such that the receiver and transmitter circuits of a commercially available 60-MHz probe⁸ were tuned for two frequencies. A circuit for accomplishing this is presented in Figure 1. In addition, the master oscillator crystals from available 24.3- and 60-MHz radiofrequency units⁹ were removed, and the outputs from two frequency synthesizers¹⁰ were attached.¹¹ Some simultaneously

(3) W. A. Anderson and R. Freeman, *J. Chem. Phys.*, **37**, 85 (1962); (b) R. Kaiser, *ibid.*, **39**, 2435 (1963); (c) K. Kuhlmann and J. D. Baldeschwieler, *J. Am. Chem. Soc.*, **85**, 1010 (1963); (d) R. A. Hoffman, B. Gestblom, and S. Forsen, *J. Chem. Phys.*, **40**, 3734 (1964); (e) R. Kaiser, *ibid.*, **42**, 1838 (1965); (f) K. F. Kuhlmann and J. D. Baldeschwieler, *ibid.*, **43**, 572 (1965); (g) F. A. L. Anet and A. J. R. Bourn, *J. Am. Chem. Soc.*, **87**, 5750 (1965).

(4) (a) A. L. Bloom and J. N. Shoolery, *Phys. Rev.*, **90**, 358(A) (1953); (b) J. N. Shoolery, Third Conference on Experimental Aspects of Nuclear Magnetic Resonance Spectroscopy, Pittsburgh, Pa., March 2–3, 1962; (c) J. D. Baldeschwieler and E. W. Randall, *Chem. Rev.*, **63**, 81 (1963); (d) D. M. Grant, Sixth Conference on Experimental Aspects of Nuclear Magnetic Resonance Spectroscopy, Pittsburgh, Pa., Feb 25–27, 1965; (e) F. J. Weigert, S. L. Manatt, and J. D. Roberts, unpublished work.

(5) The signal enhancement factor is defined as $(I - I_0)/I_0$, where I_0 is the observed signal intensity before double resonance; I is the observed signal intensity after complete decoupling.

(6) A somewhat higher range of values has been reported by P. C. Lauterbur (as quoted in ref 4c) and in ref 4d.

(7) HR-60 spectrometer, Varian Associates, Palo Alto, Calif.

(8) V-4331A probe, Varian Associates, Palo Alto, Calif.

(9) V-4311 radiofrequency units, Varian Associates, Palo Alto, Calif.

(10) Model 5100-A, Hewlett-Packard, Palo Alto, Calif.

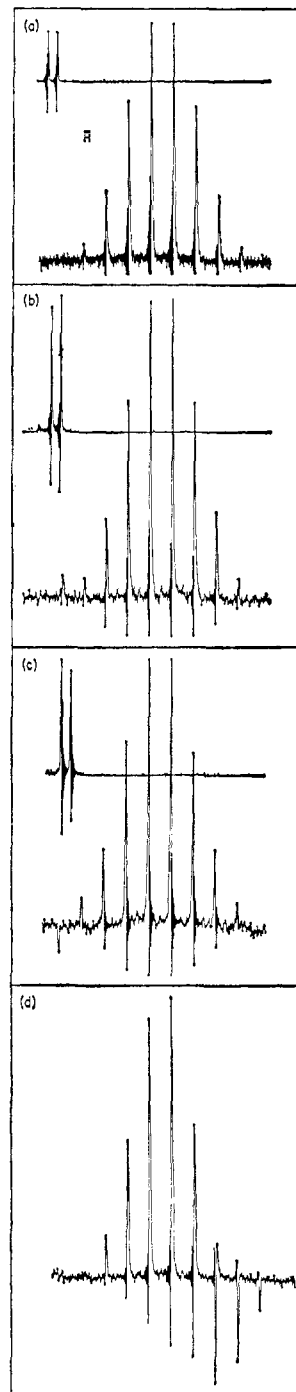

Figure 2. Simultaneously detected ^{31}P and ^1H spectra of $(\text{CF}_3\text{O})_3\text{P}$ (neat): (a) ^1H frequency, $14,996,801.65 \times 4$ MHz; ^{31}P frequency, $6,071,660.00 \times 4$ MHz; (b) frequencies as in spectrum a; ^1H radio-frequency power 22 db higher than in spectrum a; (c) ^1H frequency $14,996,803.50 \times 4$ MHz and ^{31}P frequency and ^1H power as in spectrum b; (d) frequency sweep ^{31}P spectrum; spectrometer locked on tetramethylsilane line; high-field member of ^1H doublet irradiated with weak perturbing field. Spectra a, b, and c are field swept.

recorded ^{31}P and ^1H spectra of $(\text{CH}_3\text{O})_3\text{P}$ are shown in Figure 2. Optimum observed positive and negative signal enhancements of about 10–11 are evident in the transitory selective irradiation (TSI)^{3d} experiments shown in Figures 2b and 2c. These results are larger by a factor of about 20 over any changes previously

(11) The outputs of the synthesizers were capacitively coupled to pins 1 of V-101 of each V-4311 unit. Any dc feedback is detrimental to the synthesizers.

observed in ^1H - ^1H] experiments.³ Complete decoupling of protons leads to ^{31}P enhancements of 0.5 for $(\text{CH}_3\text{O})_3\text{P}$ and 0.0 for $(\text{CH}_3)_3\text{P}$.

If a highly degenerate ^1H spectral line is irradiated in frequency-sweep experiments, as in Figure 2d, small changes (0.01 cps) in the ^1H frequency inside the apparent ^1H line width (0.15–0.30 cps) cause significant changes in ^{31}P Overhauser patterns. Systematic studies show that the ^{31}P lines with positive and negative components arise because the line widths of some ^1H transitions, part of a degenerate ^1H spectral line, are significantly less than the apparent line width. This indication of significantly different T_2 's for transitions belonging to different symmetry classes of energy levels is a heretofore unrealized complicating effect to the interpretation of Overhauser experiments. This effect is not observed if the line irradiated belongs to a single symmetry class.

(12) NASA Resident Research Associate; deceased Dec 26, 1966.
(13) Supported by the Robert A. Welch Foundation.

Daniel D. Elleman, Stanley L. Manatt, Anthony J. R. Bourn¹²
Space Sciences Division, Jet Propulsion Laboratory
California Institute of Technology, Pasadena, California 91103

Alan H. Cowley¹³
Department of Chemistry, The University of Texas
Austin, Texas 78712

Received March 3, 1967

Nuclear Magnetic Resonance of Phosphorus Compounds.

IV. The Signs of Fluorine-Phosphorus

Coupling Constants^{1,2}

Sir:

Although the magnitudes of a number of fluorine-phosphorus nuclear magnetic resonance coupling constants in fluorine- and phosphorus-containing molecules have been reported,³ only in a few instances have phosphorus-fluorine coupling-constant relative signs been established.⁴ As a part of a general study of the magnitudes and signs of nuclear resonance spin-spin coupling constants and because the absolute signs of these coupling constants are intimately related to the nature of molecular wave functions,⁵ we report here the signs of certain phosphorus-fluorine spin-spin coupling constants.

We have performed double-resonance studies on the compounds listed in Table I with the results indicated. The relative signs were established from transitory selective irradiation experiments,⁶ tickling experiments,⁷

(1) This paper presents the results of one phase of research carried out at the Jet Propulsion Laboratory, California Institute of Technology, under Contract No. NAS7-100, sponsored by the National Aeronautics and Space Administration.

(2) Previous paper in this series: D. D. Elleman, S. L. Manatt, A. J. R. Bourn, and A. H. Cowley, *J. Am. Chem. Soc.*, **89**, 4542 (1967).

(3) (a) E. L. Muetterties, W. Mahler, and R. Schmutzler, *Inorg. Chem.*, **2**, 613 (1963); (b) R. R. Holmes, R. F. Carter, Jr., and G. E. Peterson, *ibid.*, **3**, 1748 (1964); (c) J. F. Nixon and R. Schmutzler, *Spectrochim. Acta*, **20**, 1835 (1964); (d) R. Schmutzler and G. S. Reddy, *Inorg. Chem.*, **4**, 191 (1965); (e) J. F. Nixon, *J. Chem. Soc.*, 777 (1965).

(4) (a) W. Mahler, *J. Am. Chem. Soc.*, **86**, 2306 (1964); (b) R. K. Harris and C. M. Woodman, *Mol. Phys.*, **10**, 437 (1966).

(5) See M. Barfield and D. M. Grant in "Advances in Magnetic Resonance," J. S. Waugh, Ed., Academic Press Inc., New York, N. Y., 1965, pp 149–193, and references cited therein.

(6) See R. A. Hoffman, B. Gestblom, and S. Forsen, *J. Chem. Phys.*, **40**, 3734 (1964); S. Forsen and R. A. Hoffman, *Acta Chem. Scand.*, **18**, 249 (1964).

(7) R. Freeman and W. A. Anderson, *J. Chem. Phys.*, **37**, 2053 (1962).

Table I. The Signs of the Nuclear Magnetic Resonance Spin-Spin Coupling Constants between Phosphorus-31 and Fluorine-19 in Fluorophosphines

Compound	Type of nuclear spin-spin coupling	Sign
1. CF_3PH_2	F-C-P	+
	F-C-P-H	+
	P-H	+
2. $(\text{CF}_3)_2\text{PH}$	F-C-F	+
	F-C-P-H	+
	P-H	+
3. CF_3PF_2	F-C-P	+
	F-C-P-F	-
	P-F	-
4. $(\text{CF}_3)_2\text{PF}$	F-C-P	+
	F-C-P-F	-
	P-F	-
5. $\text{CF}_3\text{CF}_2\text{PCl}_2$	F-C-P	+
	F-C-C-P	+
	F-C-C-F	-
6. $\text{CF}_3^{\text{A}}\text{CF}_2^{\text{B}}\text{CF}_2^{\text{C}}\text{PCl}_2$	F-C-P	+
	F-C-C-P	+
	F-C-C-C-P	+
	F ^A -C-C-F ^B	-
	F-C-C-C-F	+
	F ^B -C-C-F ^C	? ^a
7. $(\text{CF}_3)_2\text{P-P}(\text{CH}_3)_2$	F-C-P	+
	F-C-P-P	+
	P-P	-
	H-C-P	+
	H-C-P-P	+
	F-C-P-P-C-H	+
	F-C-P-P-C-H	+
8. $\text{CF}_3\bar{\text{P}}-\overset{+}{\text{P}}(\text{CH}_3)_2$	F-C- $\bar{\text{P}}$	+
	F-C- $\bar{\text{P}}-\overset{+}{\text{P}}$	+
	$\bar{\text{P}}-\overset{+}{\text{P}}$	-
	H-C- $\overset{+}{\text{P}}$	-
	H-C- $\bar{\text{P}}-\overset{+}{\text{P}}$	+
	F-C-P-P-C-H	?

^a Probably -.

or partial collapse of multiplet structures with larger irradiation fields⁸ in the following types of double-resonance experiments: ^{31}P - ^1H], ^{31}P - ^{19}F], ^{19}F - ^{19}F], ^1H - ^{31}P], and ^{19}F - ^{31}P]. The interpretation and experimental effort were greatly reduced by simultaneous observation of the ^{31}P and ^{19}F spectra or the ^{31}P and ^1H spectra as described in the accompanying paper.² The ^{31}P frequency was always held constant and either the ^{19}F or ^1H frequency was changed.

The absolute signs given in Table I are based on the assumption that the sign of the directly bonded P-H coupling is absolute positive and that the signs of the F-C-C-F and F-C-C-C-F couplings are negative and positive, respectively.⁹ The relation of the sign of the P-H coupling to the signs of certain proton-proton

(8) K. A. McLaughlan, J. I. Musher, K. G. R. Pachler, and R. Freeman, *Mol. Phys.*, **5**, 321 (1962).

(9) R. K. Harris (private communication) has also found the same relative signs as reported here for the couplings in $(\text{CF}_3)_2\text{PF}$. In addition, he has found in $(\text{CF}_3)_2\text{PSCF}_3$ the relative signs for the F-C-P(\pm), F-C-P-S-C-F(\pm), and F-C-S-P(\pm) couplings. The latter coupling is closely analogous to the F-C-P-P couplings in $(\text{CF}_3)_2\text{P-P}(\text{CH}_3)_2$ and $\text{CF}_3\text{P-P}(\text{CH}_3)_3$ and the same sign as the F-C-P coupling.